

r.Heat® A – pipe section installation guide

Thermal insulation for pipes and fittings **r.Heat®** is made of mineral wool with density about 80 kg/m³. Product is available in reinforced aluminum jacket and without. Packaged in carton boxes with a clear product description and with an adapted opening for handy removal of the products.

r.Heat®A pipe sections are designed for thermal insulation of central heating pipes, hot and cold water, air conditioning and ventilation ducts in residential buildings, public utilities and industrial installations.

Thermal insulation pipe sections **r.Heat®A** have two cuts:
one – assembly cut and second – half cut, inside the section.

Both allow for free opening of the pipe section and easy placing it on the pipeline to be insulated. Mineral wool pipe sections **r.Heat®A** with aluminum reinforced foil ensures tightness of the insulation by placing a self-adhesive tab on its assembly. It helps in assembly, ensures continuity of insulation.

The material should be stored in packaging in dry rooms not exposed to atmospheric precipitation, moisture or dust.

Use proper sizes of the pipe sections corresponding to the pipelines. Use sharp knives to cut the sections and shapes, use the template placed on the original packaging.



Mounting instructions:

1. Before installing the cover, the pipeline should be clean, free of dust, water and grease. Uncleaned can cause contamination of glue to the surface of the overlap glue, often leading to the enlargement of the pipeline diameter, thus preventing closure of the cover.
2. The cover should be opened along the opening, the glue tab tilted and put on the pipeline.
3. After putting the **r.Heat®A** pipe section on the pipeline, the adhesive securing strip should be removed (this should not be done before applying the coating on the pipeline, as it may cause contamination to the adhesive surface), the cover pressed tightly along the slit in order to glue it together.
4. All longitudinal and transverse connections of the pipe section should be tightened and adhere closely to each other to prevent gapping that cause thermal bridges.
5. On pipe installations located horizontally, placing the cover in the upper position should be avoided to prevent the sun's rays and the heat from the piping acting on the adhesive. This might speed up the aging process of the adhesive and can cause unsealing of the the coating and heat loss. To prevent this phenomenon, folding should be located in the lower part of the cover.
6. Secure all transverse folding using aluminum tape.

Recommended method:

- Place glued circumferential areas around the section with aluminum tape,
- glue the two ends of the tape (longer and shorter) with glue to each other so that longer one protrudes beyond the other,
- glue them to the pipe section.



INSTRUCTION MANUAL – PIPE SECTIONS AND LAMELLA MATS

ROHHE

7. The aluminum tape should be smoothed with a spatula to eliminate the air between the tape and the surface of aluminum foil.

Pull the edge of the strip away from the shell

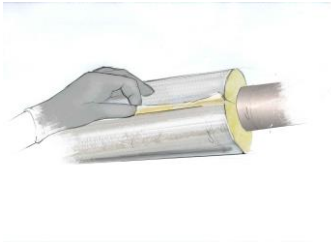

Remove the protective tape from the adhesive strip

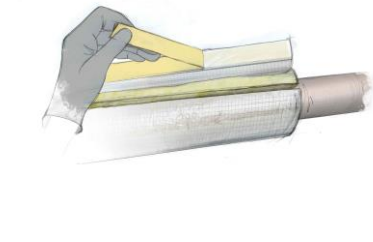

Press the pipe shells together tightly



Use aluminum tape on pipe connections



Smooth the tape with a spatula



Finished insulation from two ROHHE pipe sections



8. The aluminum self-adhesive tape is only a pre-fixing material securing and preventing the mineral wool dust from spreading out. The adhesive placed on the tape erodes over time and losing the fastening functions. Therefore, **r.Heat®A** pipe sections must be additionally secured with fastening materials as tying wire.

Use galvanized or aluminum wire on a spool, thickness of 0.65 mm. Wrap the section with a wire in the following way:

- stick one end into the section securing its sharp end,
- the other end wrap in a spiral (the number of wraps depends on the length, size and thickness of the section - from 3 to 5 wraps per running meter),
- secure the wire against slipping by putting aluminum tape on the wire insertion point
- after wrapping the pipe section, make a loop, wrap again, then secure the wire against loosening by wrapping it around the loop. Such an operation should be repeated on each section of the **r.Heat®A** pipe insulation (about 1 meter) and every fitting, each time sealing the loop with aluminum tape.

Wire fixing

Tighten the tie wire properly - repeat the

or tie a loop around the pipe section

ROHHE[®] Sp. z o.o.

Poland, 05-555 Tarczyn, Al. Krakowska 19A
www.rohhe.pl, biuro@rohhe.pl, tel. +48 22 299 88 33

operation on 3 x 1.2m



Bandage tape fixing



Cut off the remainder of the tape



and tighten the clamp

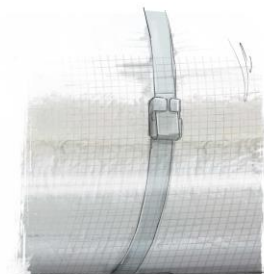

9. Fitting insulation. In the case of bent elements, such as knees or pipeline branches, a template on the carton box will certainly be useful. It allows you to accurately cut the cover at the desired angle.
10. Place the Folding on the top or bottom, while the cover is parallel to the horizontal line on the template (see the paper box). It also helps in the case of multi-part knees for symmetrical and uniform cutting of components (knee segments). Properly positioned pipe section can be cut along a certain angle depending on the type of knee we want to achieve.
After cutting the proper shape, the pipe section sleeves should be pressed firmly together and then sealed with aluminum tape and smoothed with a spatula. This method allows continuity of insulation in every place on the pipeline.
11. Closing the pipe insulation. For an aesthetic finish of the **r.Heat®A** pipe section use a sleeve or aluminum tape, remember about the distance between the insulation and the flanges, which should correspond to the total length of bolts and the 20 mm addition for easy disassembly, e.g. when replacing the flange sealing.

Insulation of pipe elbows

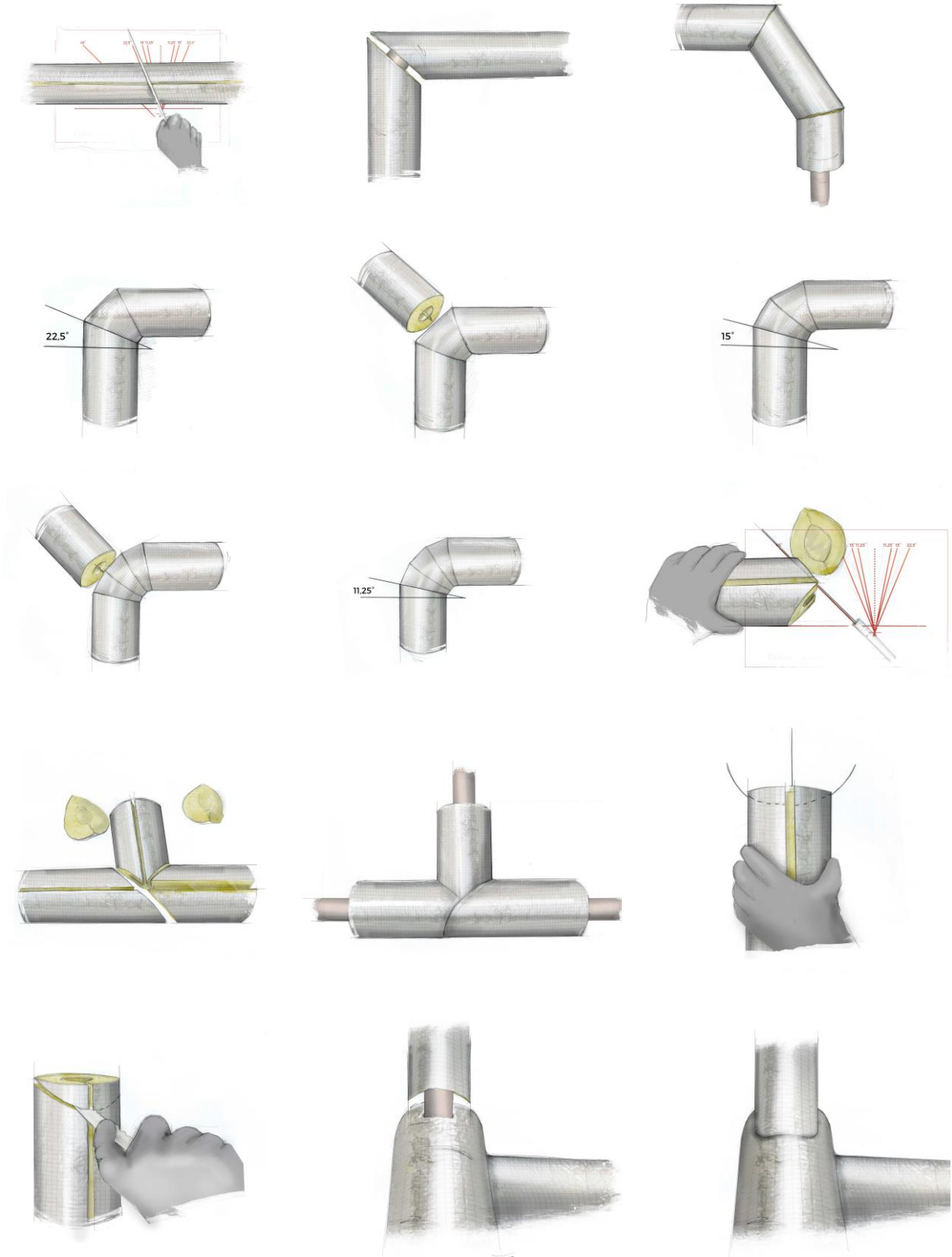

Table 1 - Thickness of pipe insulation according to series.



ROHHE

INSTRUCTION MANUAL – PIPE SECTIONS AND LAMELLA MATS

| Pipe diameter | Insulation thickness | | |
|---------------|----------------------|---------------------|---------------------|
| | Series 21 s (mm) | Series 22 s (mm) | Series 23 s (mm) |
| 10-49 | 20 | 30 | 40 |
| 50-89 | 30 | 40 | 50 |
| 90-168 | 40 | 50 | 60 |
| 170-324 | 50 | 60 | 80 |
| 325-714 | 60 | 80 | 100 |
| | Series 24 s (mm) | Series 25 s (mm) | Series 26 s (mm) |
| 10-49 | 50 | 60 | 80 |
| 50-89 | 60 | 80 | 100 |
| 90-168 | 80 | 100 | 120 |
| 170-324 | 100 | 120 | 140 |
| 325-714 | 120 | 140 | 160 |

Accessories:

- tools: sharp knife for cutting the pipe sections, spatula for smoothing the aluminum tape, measuring tape, template for cutting the section placed on the original packaging.
- tying wire used to secure the insulation,
- aluminum tape to seal the insulation against dusting,
- cuff (aluminum or PVC) with a width of 20 to 40 mm for insulation thicknesses from 20 to 100 mm, to complete the end faces of the insulation.



ROHHE[®] Sp. z o.o.

Poland, 05-555 Tarczyn, Al. Krakowska 19A
www.rohhe.pl, biuro@rohhe.pl, tel. +48 22 299 88 33



ROHHE

INSTRUCTION MANUAL – PIPE SECTIONS AND LAMELLA MATS

r.Flow® A and r.Flow® AG – lamella mats installation instructions

The aluminum-coated stone wool lamella has to be cut to size prior to installation to form a tight longitudinal cut to allow the insulation to be pressed tight against the duct surface.

For self adhesive **r.Flow® AG** lamella mat first remove the protective film and press the pre-cut lamella mat tightly onto the duct surface. The adhesive surface helps to hold the insulation in place for a more convenient later attachment with aluminum tape, metal wire or tape.

When installing insulation, the required insulation thickness must be taken into account. Insulation joints shall be installed between the duct joints.

The insulation is secured around the duct with a metal wire or ribbon (3 ties per 1.2m). 50mm or wider aluminum tape is also suitable for attachment. The 80mm hot seal tape is also suitable. Provided that all joints in the insulation mat are taped, no additional wire or metal tape is required. If the purpose of the insulation is to prevent condensation, all joints should always be sealed with tape.

For duct fittings, the insulation thickness shall be at least 80% of the normal duct insulation thickness. Insulation with thickness ≥ 120 mm At least two layers of insulation shall be installed.

For a rectangular duct, the installation depends on its purpose. To achieve thermal insulation, it is sufficient to fasten the insulation with welded or adhesive nails. To avoid loosening the insulation, keep in mind that the use of nails is mandatory at the bottom and sides of the duct. If insulation is to be used as a condensation barrier, all edges must be covered with aluminum tape.

Health and Safety:

- Insulation work should be carried out in airy rooms on installations free of dust, dirt and other contaminants not only on insulated surfaces but also on insulating material,
- If work must be carried out in rooms where it is difficult to ensure sufficient ventilation, cover the exposed parts of the body with protective clothing and use a dust mask,
- Immediately collect and remove waste from the construction site for recycling in accordance with regional regulations,
- Contact of mineral fibers with the skin may cause itching. Before washing your hands thoroughly, rinse them with warm water (cold water closes the pores in the skin of the hands) that helps the fiber particles are be discharged.
- clean the work place from dust with a vacuum cleaner.
- wear protective goggles when working over head and in windy rooms.